





LEGENDA / LEGEND

-  Bloccare con frenafili: L= Leggera - M= Media - S= Forte
Lock with the threadlocker: L= Light - M= Medium - S= Strong
-  Lubrificare ✓ / Lubricate ✓
Non lubrificare ✗ / Do not lubricate ✗
Solo primi filetti ◆ / First threads only ◆
-  Pulire e/o sgrassare
Clean and/or degrease
-  Parte della dotazione originale
Original equipment manufacturer's part



ATTENZIONE: Il montaggio del prodotto deve essere eseguito da personale specializzato.
WARNING: The mounting of the product it must be realized from staff specialist

**LATO CAMBIO
SHIFT SIDE**

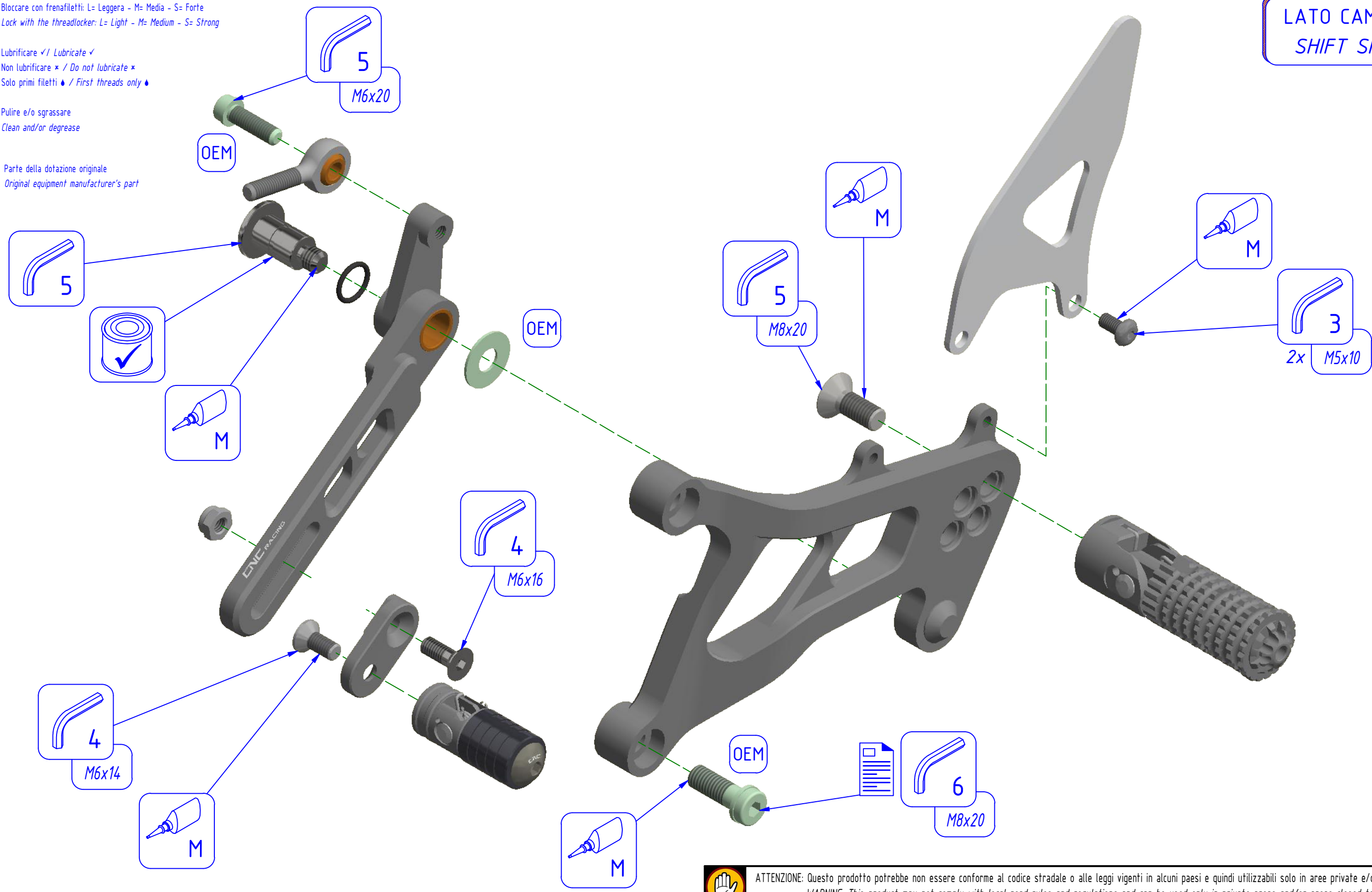

**** PER IL SERRAGGIO DELLE VITI RIFARSI AL MANUALE DEL COSTRUTTORE
** FOR THE TIGHTENING OF THE SCREWS REFER TO THE MANUFACTURER'S MANUAL**



ATTENZIONE: Questo prodotto potrebbe non essere conforme al codice stradale o alle leggi vigenti in alcuni paesi e quindi utilizzabili solo in aree private e/o chiuse al traffico.
WARNING: This product may not comply with local road rules and regulations and can be used only in private areas and/or areas closed to traffic.





ART:
PE226

ISTRUZIONI / INSTRUCTIONS
PEDANE REGOLABILI PILOTA
ADJUSTABLE RIDER REAR SETS

A termini di legge ci riserviamo la proprietà di questo disegno con divieto di riproduzione o di rendere noto a terzi senza nostra autorizzazione. / Pursuant to law, we reserve the ownership of this drawing with prohibition to copy or disclose to third parties without our authorization.

CNC RACING si riserva il diritto, a sua esclusiva discrezione, di apportare modifiche al prodotto e a queste informazioni in qualsiasi momento e senza preavviso. / CNC RACING reserves the right, in its sole discretion, to modify the product and the information at any time without prior notice.

LEGENDA / LEGEND

-  Bloccare con frenafili: L= Leggera - M= Media - S= Forte
Lock with the threadlocker: L= Light - M= Medium - S= Strong
-  Lubrificare ✓ / Lubricate ✓
Non lubrificare ✗ / Do not lubricate ✗
Solo primi filetti ◆ / First threads only ◆
-  Parte della dotazione originale
Original equipment manufacturer's part



ATTENZIONE: Il montaggio del prodotto deve essere eseguito da personale specializzato.
WARNING: The mounting of the product it must be realized from staff specialist

**LATO FRENO
BRAKE SIDE**

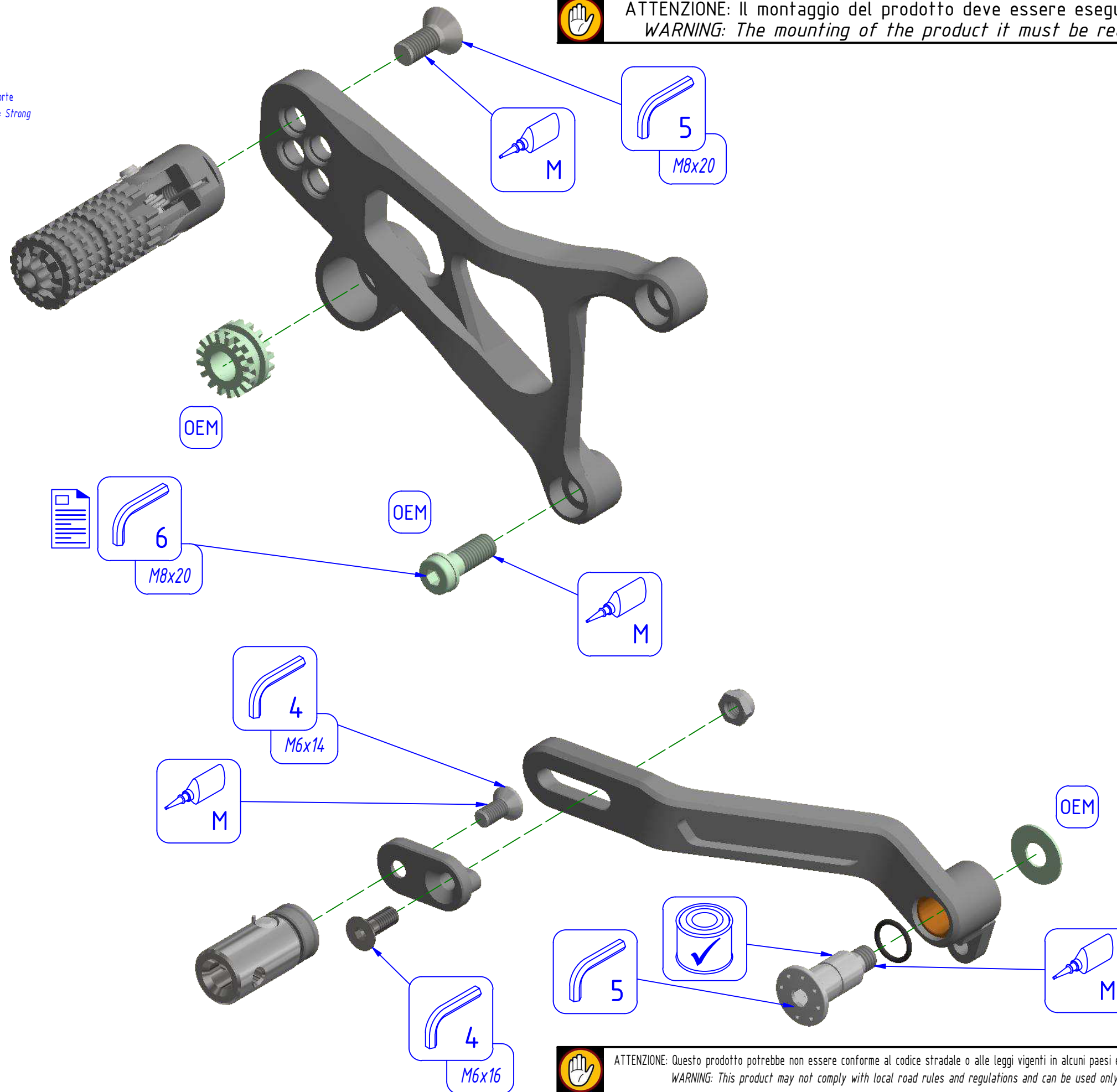

PER IL SERRAGGIO DELLE VITI RIFARSI AL MANUALE DEL COSTRUTTORE
FOR THE TIGHTENING OF THE SCREWS REFER TO THE MANUFACTURER'S MANUAL



ATTENZIONE: Questo prodotto potrebbe non essere conforme al codice stradale o alle leggi vigenti in alcuni paesi e quindi utilizzabili solo in aree private e/o chiuse al traffico.
WARNING: This product may not comply with local road rules and regulations and can be used only in private areas and/or areas closed to traffic.



ART:
PE226

ISTRUZIONI / INSTRUCTIONS
PEDANE REGOLABILI PILOTA
ADJUSTABLE RIDER REAR SETS